

TUNG-SOL

CATHODE RAY

COATED UNIPOTENTIAL CATHODE

HEATER

6.3 VOLTS 0.6 AMP.

AC OR DC

ANY MOUNTING POSITION

GLASS BULB

SMALL SHELL DUODECAL 7 PIN BASE

THE 16HP4A IS A MAGNETIC FOCUS AND MAGNETIC DEFLECTION DIRECT VIEW PICTURE TUBE FOR TELEVISION RECEIVERS. IT HAS A HIGH QUALITY GREY NEUTRAL-DENSITY FACEPLATE FOR INCREASED PICTURE CONTRAST AND DETAIL UNDER HIGH AMBIENT LIGHT CONDITIONS. THE ELECTRON GUN IS DESIGNED TO BE USED WITH AN EXTERNAL ION-TRAP MAGNET.

DESCRIPTION

FLUORESCENCE AND PHOSPHORESCENCE	WHITE
PERSISTENCE	MEDIUM
DEFLECTING AND FOCUSING METHOD	MAGNETIC
DEFLECTION ANGLE (APPROX.)	60 DEGREES
ION TRAP	MAGNETIC
BULB CONTACT	RECESSED SMALL CAVITY CAP

RATINGS

INTERPRETED ACCORDING TO RMA STANDARD W8-210

HEATER VOLTAGE	6.3	VOLTS
HEATER CURRENT	0.6	AMP.
MAXIMUM ANODE VOLTAGE	14 000	VOLTS
MAXIMUM GRID #2 VOLTAGE	410	VOLTS
MAXIMUM GRID #1 VOLTAGE:		
NEGATIVE BIAS VOLTAGE	125	VOLTS
POSITIVE BIAS VOLTAGE	0	VOLTS
POSITIVE PEAK VOLTAGE	2	VOLTS
PEAK HEATER-CATHODE VOLTAGE:		
HEATER NEGATIVE WITH RESPECT TO CATHODE:		
DURING EQUIPMENT WARM-UP PERIOD		
NOT EXCEEDING 15 SECONDS	410	VOLTS
AFTER EQUIPMENT WARM-UP PERIOD	125	VOLTS
HEATER POSITIVE WITH RESPECT TO CATHODE	125	VOLTS
MAXIMUM GRID #1 CIRCUIT RESISTANCE	1.5	MEG OHMS

TYPICAL OPERATING CONDITIONS AND CHARACTERISTICS

ANODE VOLTAGE	12 000	VOLTS
GRID #2 VOLTAGE	300	VOLTS
GRID #1 VOLTAGE (VISUAL EXTINCTION OF UNDEFLECTED FOCUSED SPOT)	-35 TO -77	VOLTS
FOCUSING COIL CURRENT (APPROX.)	110	MA.
ION TRAP CURRENT (APPROX.)	120	MA.

SIMILAR TYPE REFERENCE: The 16HP4A is identical to the 16HP4 except for the grey filter faceplate.

TUNG-SOL

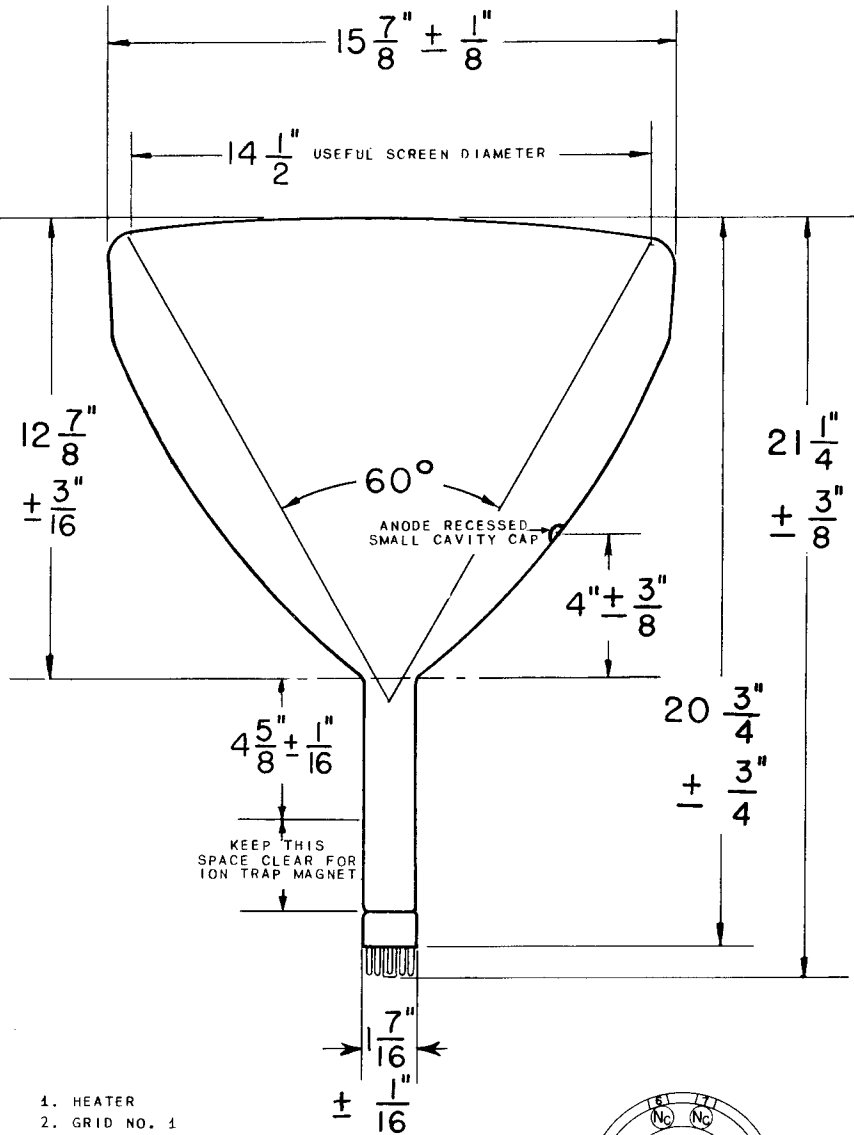

- 1. HEATER
- 2. GRID NO. 1
- 6. NO CONNECTION
- 7. NO CONNECTION
- 10. GRID NO. 2
- 11. CATHODE
- 12. HEATER
- CAP ANODE, GRID NO. 3

